



Performance by Design

# Product Data Sheet



## hamma® Standoffs Components

**Code: HM-ARC20-LAG**  
STANDOFF LAG SCREW

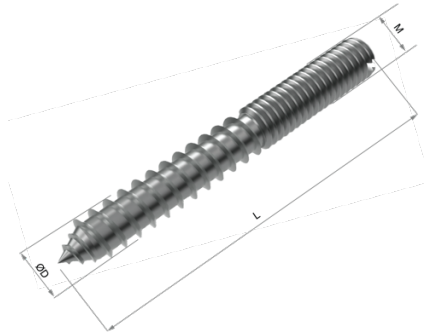

Product Code	Ø D (MM)	M	L (MM)
HM-ARC20-LAG	10	12x1.75	80

### Technical Data

- Fully Engineered
- Structural Design Certification approved
- Meets Australian / New Zealand Standard AS/NZS 1170. 1 :2002 – suitable for areas susceptible to crowding
- Meets the Building Code of Australia (BCA) National Construction Code (NCC) Volume 2 2019 – requirements for barriers and hand rails
- Various fixing details to suit project requirements
- Multiple sizing and aperture types to meet specific project parameters
- Versatility of uses of a single system include balustrading, fall-arrest, anti-climb, enclosure and screening capabilities

#### NOTE:

All measurements in mm unless otherwise stated.

Contact us on 1800 272 879 or email [sales@arcuswire.com](mailto:sales@arcuswire.com)  
[www.arcuswire.com](http://www.arcuswire.com)

hamma® is exclusively owned by Arcus Wire Group

